



Low voltage AC drives

ABB machinery drives

ACS850

0.37 to 560 kW/0.5 to 700 hp

Catalog

Power and productivity
for a better world™



Selecting and ordering your drive

Type designation is a unique reference number that clearly identifies the drive by construction, power and voltage rating and selected options. Using the type designation you can specify your drives from the wide range of options available. Options are added to the type designation using the corresponding “plus” (+) code.

Build up your own ordering code using the type designation key below or contact your local ABB drives sales office and let them know what you want. Use page 3 as a reference section for more information.

Type designation:

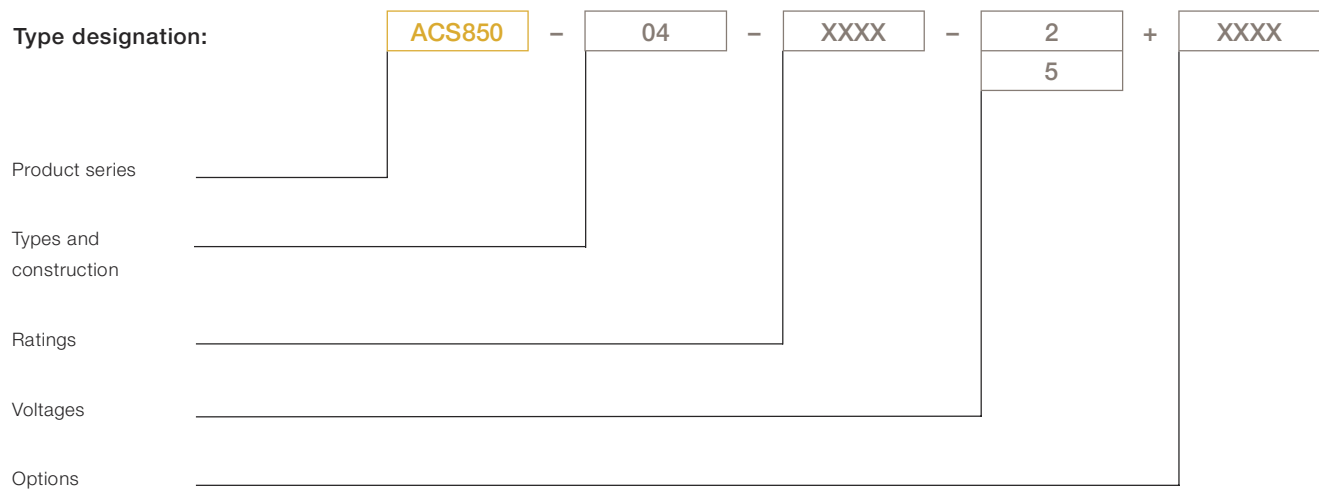

Contents

ABB machinery drives, ACS850

Introduction to ACS850	4
Main features	5
Technical data	6
Ratings, types and dimensions	7
Standard control program	9
Standard software features	10
Standard I/O	11
Options	12
Control and communication modules	12
Control panel	13
G frame drive modules	14
EMC filters	15
Mains circuit	16
PC tools	19
Crane control program	20
Synchronous reluctance motor and drive package	21
Remote monitoring and diagnostic tools	22
Expertise at every stage of the value chain	23
Secure uptime throughout the drive life cycle	23

Introduction to ACS850



ABB machinery drives are designed to meet the production and performance needs of machine builders, system integrators, panel builders and end users in a broad range of applications. ACS850 drives are ideal for applications like cranes, extruders, conveyors, winders, pumps, fans and mixers in industries such as material handling, plastic and rubber, food and beverage, textile and metals.

The drives can be configured to meet the precise needs of industries and order-based configuration is an integral part of the offering. Covering a wide power and voltage range with standard and optional features, the drives are readily programmable, making their adaptation to different applications easy.

Wide range of options

ACS850 drives offer a wide range of built-in options such as different I/O and communications. A wide selection of external accessories is also available. The flexibility and programmability of the drives make them suitable for many applications in different industries.

Robust design

The current ratings of ABB machinery drives are designed for applications that have a high overload requirement. At the heart of the drive is the motor control platform, direct torque control (DTC) that provides accurate motor torque and speed control even without feedback. The drive is designed for a long working life and as such, parts like fans and capacitors are selected to maximize their lifetime. This, together with the extensive protection features and design details such as coated boards, results in excellent reliability for the demanding industrial market.

Optimized cabinet assembly

ACS850 drives are designed to be built into a customer's own cabinet, using minimal cabinet space while ensuring that cabinet assembly is as easy as possible. The drives can be mounted side-by-side and cabinet assembly documentation is included. The documentation gives examples of different cabinet configurations, examples of drawings and hints on the selection of auxiliary equipment.



G1 and G2 modules in the picture are equipped with option +H381

Main features

Feature	Advantage	Benefit
Modular and compact design		
Compact size, side-by-side mounting	Smallest frame size is only 93 mm (4 in) wide. More drives can be placed in the same cabinet.	Optimum installation layout and efficient cabinet space usage. Space and cost savings.
Modular design	Many standard features and a wide range of options allow different system configurations.	Fits many application needs. Offers flexibility in system design.
User interface and programming		
Intuitive human-machine interface	Large alphanumeric display showing different assistants and macros.	Faster and more accurate drive configuration. Optimal drive settings as assistants offer interactive help.
Drive programming and configuration	Can replace relays and small PLCs with function block programming.	Lower investment cost. Higher flexibility in system design.
Memory unit for easy drive management	Complete drive configuration and settings are stored in a separate memory unit. Power or control unit can be replaced without parameter setting.	Drive functionality can be easily configured, modified or updated with the memory unit. Offers quick and easy after-sales service.
Designed for reliability		
Robust main circuit design	Enhanced reliability. Coated boards and long lifetime components. Cooling supervision (depending on frame size).	Less process interruptions. Lower maintenance costs.
Extensive protection	Advanced thermal protection of the drive semiconductors and motor.	Higher process uptime. Early warning of any production interruptions.
Maintenance assistant	Indicates preventive maintenance needs of drive, motor or machine.	Helps with maintenance schedules and cost control of maintenance.
Diagnostic assistant	Helps in locating failures or reasons for performance changes and suggests remedies.	Reduced process downtime.
Optimized use		
Energy saving calculator	Monitors used and saved energy, displayed in kWh, currency (€ or \$) or volume of CO ₂ emission.	Easy to check the return on investment.
Load analyzer	Shows the load profile of the drive.	Easy process analysis.
Energy optimizer	Maximizes efficiency by optimizing the motor flux.	Improves motor performance therefore making the process more efficient.
Control and performance		
Compatible with these AC motors: - induction - permanent magnet - synchronous reluctance	Same drive can be used to control different motor types.	Savings in investment costs.
Standard drive-to-drive link, configurable as Modbus link	Galvanic isolated connection for master-follower communication or Modbus.	Lower investment costs. More reliable, disturbance-free isolation.
Different communication options	Supports most common communication protocols.	Can be applied to several existing processes.
Integrated safe torque off function (up to SIL 3)	High SIL class means high reliability of the safety function. Can also be used to implement Emergency Stop without contactors.	Cost-effective and certified solution for safe machine maintenance. Fulfils IEC 61508, EN 62061 and EN ISO 13849-1 standards.
Extensive configurable standard I/Os	Optimized accessibility.	Lower cost. Fewer parts and installation work needed for cabinet assembly.
Optional I/O extensions	Plug-in analog and digital I/O extensions.	Extends drives' scope, performance and applications opportunities.
Direct torque control	Accurate, dynamic and static speed and torque control. Excellent process control even without pulse encoder. High overload and high starting torque. Less noise during motor operation. Output frequency up to 500 Hz. Enhanced motor identification at standstill.	Improves product quality, productivity and reliability. Lower investment cost. Less maintenance. Suitable for use where audible noise is an issue. Applicable in high speed applications. Better process control due to more accurate identification. Motor identification without decoupling the load.

Technical data



Mains connection	
Supply voltage	3-phase 380 to 500 V AC +10 /-15% 3-phase 200 to 240 V AC ± 10%
Frequency	50 to 60 Hz ± 5%
DC connection	
DC voltage level	485 to 675 V DC ± 10% (-5 types) 270 to 324 V DC ± 10% (-2 types)
Charging circuit	Internal in frames A to D External in frames E0 to G2
Motor connection	
Motor types	AC induction motors, permanent magnet motors and synchronous reluctance motors
Output frequency	0 to 500 Hz
Motor control	Direct torque control (DTC) or scalar control
Torque control:	Torque step rise time:
Open loop	<5 ms with nominal torque
Closed loop	<5 ms with nominal torque
	Non-linearity:
Open loop	± 4% with nominal torque
Closed loop	± 3% with nominal torque
Speed control:	Static accuracy:
Open loop	10% of motor slip
Closed loop	0.01% of nominal speed
	Dynamic accuracy:
Open loop	0.3 to 0.4% sec. with 100% torque step
Closed loop	0.1 to 0.2% sec. with 100% torque step
Braking power connection	
Brake chopper	Standard in frames A to D, built-in option in the other frame sizes
Brake resistor	External resistor connected to drive

Operating conditions	
Degree of protection	IP20 according to EN 60529 (G frames IP00); Open type according to UL 508
Ambient temperature	-10 to +55 °C (14 to 131 °F), derating above 40 °C (104 °F) No frost allowed
Installation altitude	0 to 4000 m (0 to 13000 ft) (IT network: 2000 m [6560 ft]), derating above 1000 m (3280 ft): 1%/100 m (328 ft)
Relative humidity	Max. 95%, no condensation allowed
Climatic/ environmental conditions	Class 3K3, 3C2 according to EN 60721-3-3. Oil mist, formation of ice, moisture condensation, water drops, water spray, water splashes and water jets are not permissible (EN 60204, Part 1)
Vibration	Class 3M4 according to EN 60721-3-3
EMC (According to EN 61800-3)	Categories C2 and C3 with optional filter (according to EN 61800-3)
Functional safety	Safe torque off (STO according to EN 61800-5-2) IEC 61508: SIL 3 IEC 61511: SIL3 EN 62061: SILCL 3 EN ISO 13849-1: PL e Certified by TÜV
Compliance	Frames A to D: CE, GOST R, UL, cUL, CSA, C-Tick Frames E0 to G: CE, GOST R; pending: UL, cUL, CSA, C-Tick

Feature/frame size	A	B	C	D	E0	E	G1	G2
Current and power								
Nominal current	3 to 8 A	10.5 to 18 A	25 to 50 A	61 to 94 A	103 to 144 A	166 to 290 A	387 to 650 A	710 to 875 A
Maximum current	4.4 to 10.5 A	13.5 to 21 A	33 to 66 A	78 to 124 A	138 to 170 A	202 to 348 A	470 to 730 A	850 to 1100 A
Typical motor power in kW (230 V)	0.37 to 1.5 kW	2.2 to 4 kW	5.5 to 11 kW	15 to 22 kW	-	-	-	-
(400 V)	1.1 to 3 kW	4 to 7.5 kW	11 to 22 kW	30 to 45 kW	55 to 75 kW	90 to 160 kW	200 to 355 kW	400 to 500 kW
(500 V)	1.5 to 4 kW	5.5 to 11 kW	15 to 30 kW	37 to 55 kW	55 to 90 kW	110 to 200 kW	250 to 400 kW	500 to 560 kW
Typical motor power in hp (230 V)	0.5 to 2 hp	3 to 5 hp	7.5 to 15 hp	20 to 30 hp	-	-	-	-
(480 V)	1.5 to 5 hp	5 to 10 hp	15 to 30 hp	40 to 60 hp	75 to 100 hp	125 to 200 hp	300 to 550 hp	600 to 700 hp
Brake chopper	●	●	●	●	□	□	□	□
Brake resistor	■	■	■	■	■	■	■	■
Input choke	■	■	●	●	●	●	●	●
EMC filter/C2	■	■	■	■	□	□	-	-
EMC filter/C3	■	■	□	□	□	□	●	●
Mounting and cooling								
Air cooling	●	●	●	●	●	●	●	●
Side-by-side mounting	●	●	●	●	●	●	●	●
DIN rail mounting	●	●	-	-	-	-	-	-
Removable power connectors	●	●	-	-	-	-	-	-
Removable control connectors	●	●	●	●	●	●	●	●

● = standard □ = option, built-in ■ = option, external - = not available

Ratings, types and dimensions



Ratings 230 V

Nominal ratings		No-overload use		Light-duty use			Heavy-duty use			Type designation	Frame size
I_{2N} (A)	I_{max} (A)	P_N (kW) $U_N = 230$ V	P_N (hp) $U_N = 230$ V	I_{Ld} (A)	P_{Ld} (kW) $U_N = 230$ V	P_{Ld} (hp) $U_N = 230$ V	I_{Hd} (A)	P_{Hd} (kW) $U_N = 230$ V	P_{Hd} (hp) $U_N = 230$ V		
3	4.4	0.37	0.5	2.8	0.37	0.5	2.5	0.37	0.5	ACS850-04-03A0-2	A
3.6	5.3	0.55	0.75	3.4	0.55	0.75	3	0.37	0.5	ACS850-04-03A6-2	A
4.8	7	0.75	1	4.5	0.75	1	4	0.55	0.75	ACS850-04-04A8-2	A
6	8.8	1.1	1.5	5.5	1.1	1	5	0.75	1	ACS850-04-06A0-2	A
8	10.5	1.5	2	7.6	1.5	2	6	1.1	1.5	ACS850-04-08A0-2	A
10.5	13.5	2.2	3	9.7	2.2	3	9	1.5	2	ACS850-04-010A-2	B
14	16.5	3	3	13	3	3	11	2.2	3	ACS850-04-014A-2	B
18	21	4	5	16.8	4	5	14	3	3	ACS850-04-018A-2	B
25	33	5.5	7.5	23	5.5	7.5	19	4	5	ACS850-04-025A-2	C
30	36	7.5	10	28	7.5	10	24	5.5	7.5	ACS850-04-030A-2	C
35	44	7.5	10	32	7.5	10	29	7.5	10	ACS850-04-035A-2	C
44	53	11	15	41	11	15	35	7.5	10	ACS850-04-044A-2	C
50	66	11	15	46	11	15	44	11	15	ACS850-04-050A-2	C
61	78	15	20	57	15	20	52	11	15	ACS850-04-061A-2	D
78	100	18.5	25	74	18.5	25	66	15	20	ACS850-04-078A-2	D
94	124	22	30	90	22	30	75	18.5	25	ACS850-04-094A-2	D

Ratings 400 to 500 V

Nominal ratings		No-overload use			Light-duty use				Heavy-duty use				Type designation	Frame size
I_{2N} (A)	I_{max} (A)	P_N (kW) $U_N = 400$ V	P_N (kW) $U_N = 500$ V	P_N (hp) $U_N = 480$ V	I_{Ld} (A)	P_{Ld} (kW) $U_N = 400$ V	P_{Ld} (kW) $U_N = 500$ V	P_{Ld} (hp) $U_N = 480$ V	I_{Hd} (A)	P_{Hd} (kW) $U_N = 400$ V	P_{Hd} (kW) $U_N = 500$ V	P_{Hd} (hp) $U_N = 480$ V		
3	4.4	1.1	1.5	1.5	2.8	1.1	1.1	1	2.5	0.75	1.1	1	ACS850-04-03A0-5	A
3.6	5.3	1.5	1.5	2	3.4	1.5	1.5	2	3	1.1	1.5	1.5	ACS850-04-03A6-5	A
4.8	7	2.2	2.2	3	4.5	1.5	2.2	2	4	1.5	2.2	2	ACS850-04-04A8-5	A
6	8.8	2.2	3	3	5.5	2.2	3	3	5	2.2	2.2	3	ACS850-04-06A0-5	A
8	10.5	3	4	5	7.6	3	4	5	6	2.2	3	3	ACS850-04-08A0-5	A
10.5	13.5	4	5.5	5	9.7	4	5.5	5	9	4	4	5	ACS850-04-010A-5	B
14	16.5	5.5	7.5	7.5	13	5.5	7.5	7.5	11	5.5	5.5	7.5	ACS850-04-014A-5	B
18	21	7.5	11	10	16.8	7.5	7.5	10	14	7.5	7.5	10	ACS850-04-018A-5	B
25	33	11	15	15	23	11	11	15	19	7.5	11	10	ACS850-04-025A-5	C
30	36	15	18.5	20	28	15	15	20	24	11	15	15	ACS850-04-030A-5	C
35	44	18.5	22	25	32	15	18.5	20	29	15	18.5	20	ACS850-04-035A-5	C
44	53	22	30	30	41	22	22	30	35	18.5	22	25	ACS850-04-044A-5	C
50	66	22	30	30	46	22	30	30	44	22	30	30	ACS850-04-050A-5	C
61	78	30	37	40	57	30	37	40	52	22	30	40	ACS850-04-061A-5	D
78	100	37	45	60	74	37	45	50	66	37	45	50	ACS850-04-078A-5	D
94	124	45	55	60	90	45	55	60	75	37	45	50	ACS850-04-094A-5	D
103	138	55	55	75	100	55	55	75	83	45	55	60	ACS850-04-103A-5	E0
144	170	75	90	100	141	75	90	100	100	55	55	75	ACS850-04-144A-5	E0
166	202	90	110	125	155	75	90	125	115	55	75	75	ACS850-04-166A-5	E
202	282	110	132	150	184	90	110	150	141	75	90	100	ACS850-04-202A-5	E
225	326	110	132	150	220	110	132	150	163	90	110	125	ACS850-04-225A-5	E
260	326	132	160	200	254	132	160	200	215	110	132	150	ACS850-04-260A-5	E
290	348	160	200	200	286	160	200	200	232	132	160	150	ACS850-04-290A-5	E
387	470	200	250	300	377	200	250	300	300	160	200	200	ACS850-04-387A-5	G1
500	560	250	315	350	480	250	315	350	355	200	250	250	ACS850-04-500A-5	G1
580	680	315	355	450	570	315	355	450	414	200	250	350	ACS850-04-580A-5	G1
650	730	355	400	500	634	355	400	500	477	250	315	400	ACS850-04-650A-5	G1
710	850	400	500	600	700	400	500	600	566	315	400	450	ACS850-04-710A-5	G2
807	1020	450	560	700	785	450	560	600	625	355	450	500	ACS850-04-807A-5	G2
875	1100	500	560	700	857	450	560	700	680	400	450	600	ACS850-04-875A-5	G2

Notes

- For ambient temperature of less than 35 °C (95 °F), maximum overload is 150% of I_{Hd} . For ambient temperature of 40 °C (104 °F), maximum overload is 145% of I_{Hd} .
- For ambient temperature of less than 30 °C (86 °F), maximum overload is 150% of I_{Hd} . For ambient temperature of 40 °C (104 °F), maximum overload is 140% of I_{Hd} .

Nominal ratings

I_{2N} Rated current available continuously without overloading at 40 °C (104 °F).
 I_{max} Maximum output current. Available for 10 s at start, otherwise as long as allowed by drive temperature. Note: max. motor shaft power is 150% P_{Hd} .

Typical ratings: No-overload use

P_N Typical motor power in no-overload use.

Light-duty use

I_{Ld} Continuous current allowing 110% I_{Hd} for 1 min/5 min at 40 °C (104 °F).
 P_{Ld} Typical motor power in light-duty use.

Heavy-duty use

I_{Hd} Continuous current allowing 150% I_{Hd} for 1 min/5 min at 40 °C (104 °F).
 P_{Hd} Typical motor power in heavy-duty use.

The current ratings are the same regardless of the supply voltage within one voltage range. The ratings apply at 40 °C (104 °F) ambient temperature.

Ratings, types and dimensions



Cooling characteristics and noise levels

Heat dissipation W	Air flow m ³ /h (ft ³ /min)	Noise level dBA	Type designation	Frame size
U_N = 400 V				
100	24 (14)	47	ACS850-04-03A0-5	A
106	24 (14)	47	ACS850-04-03A6-5	A
126	24 (14)	47	ACS850-04-04A8-5	A
148	24 (14)	47	ACS850-04-06A0-5	A
172	24 (14)	47	ACS850-04-08A0-5	A
212	48 (28)	39	ACS850-04-010A-5	B
250	48 (28)	39	ACS850-04-014A-5	B
318	48 (28)	39	ACS850-04-018A-5	B
375	142 (84)	71	ACS850-04-025A-5	C
485	142 (84)	71	ACS850-04-030A-5	C
513	142 (84)	71	ACS850-04-035A-5	C
541	200 (118)	71	ACS850-04-044A-5	C
646	200 (118)	71	ACS850-04-050A-5	C
840	290 (171)	70	ACS850-04-061A-5	D
1020	290 (171)	70	ACS850-04-078A-5	D
1200	290 (171)	70	ACS850-04-094A-5	D
1190	168 (99)	65	ACS850-04-103A-5	E0
1440	405 (238)	65	ACS850-04-144A-5	E0
1940	405 (238)	65	ACS850-04-166A-5	E
2310	405 (238)	65	ACS850-04-202A-5	E
2819	405 (238)	65	ACS850-04-225A-5	E
3260	405 (238)	65	ACS850-04-260A-5	E
4200	405 (238)	65	ACS850-04-290A-5	E
4403	1200	72*	ACS850-04-387A-5	G1
5602	1200	72*	ACS850-04-500A-5	G1
6409	1200	72*	ACS850-04-580A-5	G1
8122	1200	72*	ACS850-04-650A-5	G1
8764	1200	72*	ACS850-04-710A-5	G2
9862	1200	72*	ACS850-04-807A-5	G2
10578	1420	72*	ACS850-04-875A-5	G2

Heat dissipation W	Air flow m ³ /h (ft ³ /min)	Noise level dBA	Type designation	Frame size
U_N = 230 V				
91	24 (14)	47	ACS850-04-03A0-2	A
97	24 (14)	47	ACS850-04-03A6-2	A
114	24 (14)	47	ACS850-04-04A8-2	A
134	24 (14)	47	ACS850-04-06A0-2	A
154	24 (14)	47	ACS850-04-08A0-2	A
183	48 (28)	39	ACS850-04-010A-2	B
215	48 (28)	39	ACS850-04-014A-2	B
274	48 (28)	39	ACS850-04-018A-2	B
325	142 (84)	71	ACS850-04-025A-2	C
421	142 (84)	71	ACS850-04-030A-2	C
442	142 (84)	71	ACS850-04-035A-2	C
462	200 (118)	71	ACS850-04-044A-2	C
555	200 (118)	71	ACS850-04-050A-2	C
730	290 (171)	70	ACS850-04-061A-2	D
889	290 (171)	70	ACS850-04-078A-2	D
1054	290 (171)	70	ACS850-04-094A-2	D

* 65 dBA standby - 72 dBA running.

Dimensions

Frame size	Height ¹⁾		Depth ^{2) 3)}		Width		Weight	
	mm	in	mm	in	mm	in	kg	lb
A	364	14.3	197	7.8	93	3.7	3	7
B	380	15.0	274	10.8	101	4.0	5	11
C	567	22.3	276	10.9	166	6.5	16	35
D	567	22.3	276	10.9	221	8.7	23	51
E0	602	23.7	354	13.9	276	10.9	35	77
E	700	27.6	443	17.4	312	12.3	67	147
G1	1462 (1560) ⁴⁾	57.6 (61.4) ⁴⁾	505 (515) ⁴⁾	19.9 (20.3) ⁴⁾	305 (329) ⁴⁾	12 (13) ⁴⁾	161 (191) ⁴⁾	355 (421) ⁴⁾
G2	1662 (1710) ⁴⁾	65.4 (67.3) ⁴⁾	505 (515) ⁴⁾	19.9 (20.3) ⁴⁾	305 (329) ⁴⁾	12 (13) ⁴⁾	199 (229) ⁴⁾	439 (505) ⁴⁾

Notes

All dimensions and weights are without additional options.

¹⁾ Height is the maximum measure without clamping plates.

²⁾ An additional 50 mm (2 in) should be reserved for feedback cabling if FEN-01, -11 or -21 options are used (except for frame G1 and G2 with integrated control unit).

³⁾ Assistant control panel adds 23 mm (0.9 in) to the depth (except for frame G1 and G2 with integrated control unit).

⁴⁾ With +H381 optional cabling panel.

Standard control program

Based on direct torque control technology, the ACS850 offers highly advanced features. The ACS850 standard control program provides solutions to virtually all AC drives applications such as mixers, separators, extruders and conveyors.

Fast and easy commissioning

The ACS850 standard control program offers flexibility and extensive parameter settings. It consists of a simple, ready-made program that can easily be modified to meet specific application needs. Commissioning is also simplified by several standard software features.

Pre-programmed protection functions

A wide range of features provide protection for the drive, motor and the process:

- Ambient temperature
- DC overvoltage
- DC undervoltage
- Drive temperature
- Input phase loss
- Overcurrent
- Power limits
- Short circuit

Programmable protection functions:

- Adjustable power limits
- Control signal supervision
- Critical frequencies lock-out
- Current and torque limits
- Earth fault protection
- External fault
- Motor phase loss
- Motor stall protection
- Motor thermal protection
- Motor underload protection
- Panel loss

Program customization

In addition to standard control program functionalities the ACS850 offers function block programming which makes it possible to replace relays or even a PLC.

Removable memory unit

A removable memory unit provides easy maintenance by storing the complete firmware including all user settings and motor data. Thus, if the power unit or control unit is replaced, the drive can be re-commissioned without any reprogramming, just by moving the memory unit.

The removable memory unit:

- Stores the drive software and parameter settings
- Allows fast and easy recommissioning
- Enables software and parameter configuration at workshop instead of doing it on-site



Standard software features

The features of ACS850 drives are designed to enhance their reliability and durability as well as the easiness of use. Also several advanced functions make the drives easy to use. These functions can be accessed either via the user-friendly assistant control panel or DriveStudio PC tool.

Macros

Several macros which have pre-set, application-specific parameter settings are available as standard in each drive. These pre-programmed parameter settings enable fast and easy commissioning by adjusting all the relevant parameters in just a couple of clicks.

Startup assistant

The intelligent and intuitive startup assistant allows first time users to quickly get up to speed and customize the drive according to their needs. This is complemented by a built-in help function to make parameter-by-parameter setting easy. This way the drive can be quickly commissioned, even without manuals.

Maintenance assistant

The maintenance assistant reminds the user about the drive's preventive maintenance schedule or routine, or that of its associated components such as motor, cabinet air

inlet filters and input contactors. It reminds users of planned maintenance needs based on running hours, operating hours or relay switching to reduce unplanned process interruptions.

Diagnostic assistant

Each ACS850 drive is equipped with a diagnostic assistant that helps in locating the cause of any disturbance to the drive and even suggests possible remedies. This reduces process downtime by making repair or adjustments quicker and easier.

Energy saving features

- A calculator showing the used and saved energy, displayed in kWh, currency (€ or \$) or volume of CO₂ emission. Data is calculated by reference values stored in the drive by the user.
- An energy efficiency optimizer that adjusts the motor flux, such a way that the total efficiency is maximized.
- A load analyzer showing the load profile of the drive.

Short/long menus

The user interface can be configured so that it displays only the most common parameters. This short menu allows users to quickly access the parameters they need without having to go through all the drive parameters.

A long menu is available, displaying a complete list of parameters for a more advanced configuration.

Input and output mapping

This functionality allows the user to easily go through the input and output configuration of the drive.

List of changed parameters

The feature allows users to go through the list of changed parameters. This way the user does not have to go through all the drive parameters making it quick to identify the recently modified ones.



Standard I/O



Standard I/O connections

ACS850 drives have one of the most extensive offerings of standard I/Os on the market. Analog and digital I/O channels are used for different functions such as control, monitoring and measurement purposes (eg, motor temperature).

- Control voltage supply: external supply (24 V DC) input for the control unit
- Digital I/O: 6 x DI, 2 x DO can be used also for pulse train inputs or outputs, max 32 kHz, 3 x RO
- Analog I/O: 2 x AI (mA or V), 2 x AO (mA)
- Thermistor input: motor thermistor (PTC)
- Start interlock: drive interlock input
- Embedded Modbus link as standard, galvanically isolated for trouble-free operation and can be alternatively configured as a high speed drive-to-drive link for master-follower operation
- Safe torque off (STO) designed for Safety Integrity Level 3 (SIL 3) according to IEC 61508
- Control panel connection: PC tools and control panel connection (RJ45)
- Memory unit connection: complete drive configuration and settings are stored in the removable memory unit

Control unit

The ACS850 control unit consists of various control connections, which can be configured as required by the customer application.

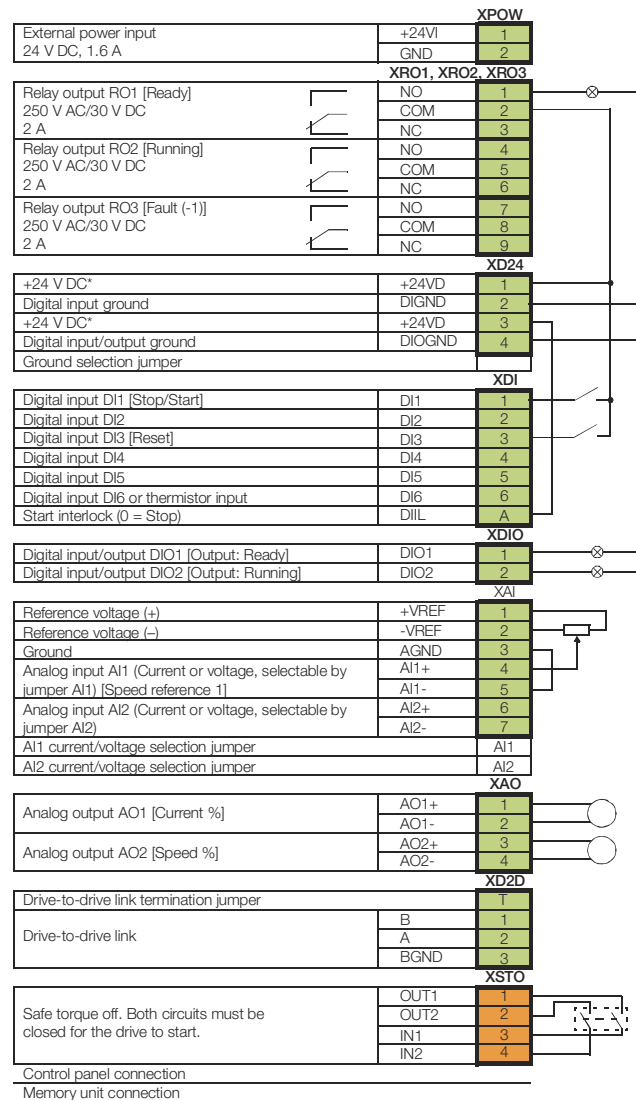
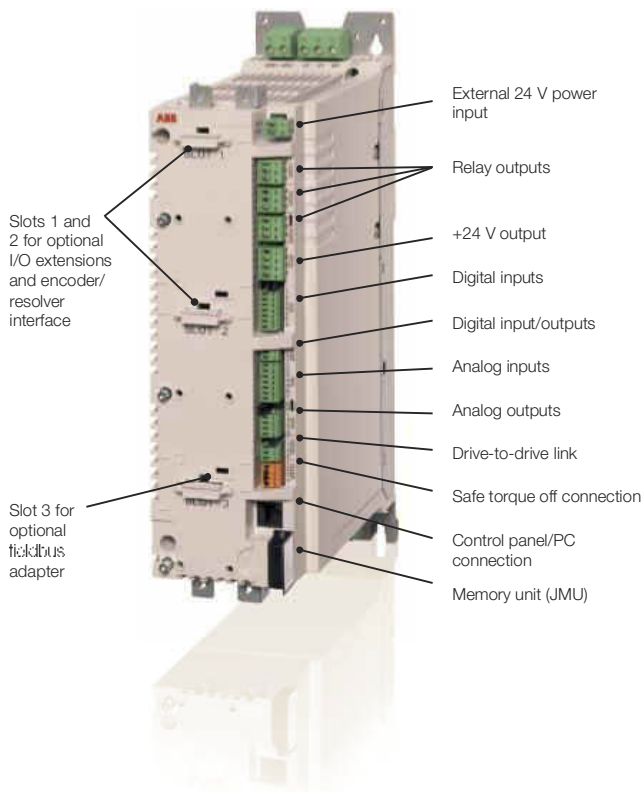

*Total maximum current: 200 mA

Options

Control and communication modules



Optional I/O

The optional I/O extension modules provide additional connectivity possibilities for ACS850 drives. Extensions include analog and digital modules and speed feedback interface modules which are mounted in the slots on the ACS850 control board. The control board has two slots available for I/O extension modules. Additionally, there is a third slot available for fieldbus adapter modules.

Fieldbus adapter modules

A wide range of fieldbus protocols are supported to enable the ACS850 to connect to major automation systems. Fieldbus adapter modules allow manufacturing flexibility, reduced installation and engineering effort via:

- Drive control
- Drive monitoring
- Drive diagnostics
- Drive parameter handling



Options	Option codes	Data	Install in
Analog and digital extension modules			
FIO-01	+L501	4 x DI/O, 2 x RO	Slot 1 or 2
FIO-11	+L500	3 x AI (mA/V), 1 x AO (mA), 2 x DI/O	
FIO-21	+L519	1 x AI (mA/V), 1 x AO (mA), 1 x DI, 2 x RO	
Feedback interface modules			
FEN-01	+L517	2 inputs (TTL incremental encoder), 1 output	Slot 1 or 2
FEN-11	+L518	2 inputs (SinCos absolute, TTL incremental encoder), 1 output	
FEN-21	+L516	2 inputs (Resolver, TTL incremental encoder), 1 output	
FEN-31	+L502	1 input (HTL incremental encoder), 1 output	
Fieldbus adapter modules			
FPBA-01	+K454	PROFIBUS DP, DPV0/DPV1	Slot 3
FCAN-01	+K457	CANopen®	
FDNA-01	+K451	DeviceNet™	
FENA-11	+K473	EtherNet/IP™, Modbus TCP, PROFINET IO	
FSCA-01	+K458	Modbus RTU	
FECA-01	+K469	EtherCAT®	
FLON-01	+K452	LonWorks®	

Options

Control panel

ACS850 - 04 - XXXX -

2
5

 + XXXX

Assistant control panel

The assistant control panel features a multilingual alphanumeric display for easy drive configuration. It is an ideal tool for service engineers, providing the following features:



- A large alphanumeric display
- Easy navigation
- Soft and convenient keys
- Local control keys (start/stop/reference)
- Parameter setting and monitoring
- Status and history data
- Real-time clock

Assisting functionalities like:

- Startup assistant
- Maintenance assistant
- Diagnostic assistant



Assistant control panel options

There are various cover assembly options for the ACS850. The cover is mounted on the drive depending on the specific need of the customer application.

Standard control unit cover

The control unit cover comes as standard without an assistant control panel and holder.



Control unit cover with assistant control panel (+J400)

Includes the assistant control panel, a control unit cover with a panel holder and an internal interface cable.



Control unit cover with panel holder (+J414)

Includes the control unit cover with a panel holder, a panel cover and an internal interface cable.



Door mounting kit with assistant control panel (+J410)

Includes the assistant control panel and a panel holder for cabinet door mounting, with IP54 kit and 3 m (10 ft) cable.



Options

G frame drive modules



The ACS850 G1 and G2 frames have some useful optional features. For ordering codes and description see the table below.

Options	Description
+D150	Braking chopper + connection busbars
+E208	Common mode filter
+H356	DC connection busbars
+H381	Power cabling panels
+0H354	Without pedestal
+P905	Integrated control unit

The cabling panel option allows easy connection of input power and motor cables. The cabling panel enables cabinet drive module installing and removing without the need of disconnecting cables.

As a standard, the G1 and G2 frames have an external control unit. This allows easy and safe installation of control cabling. With the integrated control unit option (+P905), the control unit is located inside the drive module making the installation space requirement compact.



Cabling panel option +H381



Standard drive module delivery includes external control unit. The control panel +J400 comes as an option.



Optional +P905 (integrated) control unit with control panel (+J400)

Options

EMC filters



Electromagnetic Compatibility (EMC) and modules

The electrical/electronic equipment must be able to operate without problems within an electromagnetic environment. This is called immunity. The ACS850 is designed to have adequate immunity against interference from other equipment. Likewise, the equipment must not disturb or interfere with any other product or system within its locality. This is called emission. Each ACS850 model can be equipped with a built-in filter to reduce high frequency emission.

EMC standards

The EMC product standard EN 61800-3 (2004) covers the specific EMC requirements stated for drives (tested with motor and cable) within the EU.

EMC standards such as EN 55011, or EN 61000-6-3/4, are applicable to industrial and domestic equipment and systems including drive components inside. Drive units complying with requirements of EN 61800-3 are compliant with comparable categories in EN 55011 and EN 61000-6-3/4, but not necessarily vice versa. EN 55011 and EN 61000-6-3/4 do not specify cable length nor require a motor to be connected as a load. The emission limits are comparable according to the following EMC standards table.

1st environment vs 2nd environment

1st environment (category C1 to C2)

1st environment includes domestic premises. It also includes establishments directly connected without intermediate transformer to a low-voltage power supply network which supplies buildings used for domestic purposes.

2nd environment (category C3 to C4)

2nd environment includes all establishments other than those directly connected to a low-voltage power supply network which supplies buildings used for domestic purposes.

Selecting an EMC filter

The following table gives the correct filter selection.

EMC standards

EN61800-3 (2004) product standard	EN 55011, product family standard for industrial, scientific and medical (ISM) equipment	EN 61000-6-4, generic emission standard for industrial environments	EN 61000-6-3, generic emission standard for residential, commercial and light-industrial environment
Category C1 (1 st environment)	Group 1 Class B	Not applicable	Applicable
Category C2 (1 st environment)	Group 1 Class A	Applicable	Not applicable
Category C3 (2 nd environment)	Group 2 Class A	Not applicable	Not applicable
Category C4 (2 nd environment)	Not applicable	Not applicable	Not applicable

EMC category / frame	Option code	A to B	C to D	E0 to E	G1 to G2
C3 filter, earthed/unearthed network *	+E210	–	–	<input type="checkbox"/>	<input type="checkbox"/>
C3 filter earthed network only *	+E200	■ ¹⁾	<input type="checkbox"/>	–	–
C2 filter, earthed network only *	+E202	–	–	<input type="checkbox"/>	–
C2 filter, earthed network only *		■ ²⁾	■ ²⁾	–	–

= option, built-in = option, external – = not available

Notes

¹⁾ External, plug-in

²⁾ External accessory, no plus code

* Max. cable length 100 m (328 ft)

Options

Mains circuit



Mains chokes

Mains chokes are typically used to reduce harmonics in the mains current. Frames C to G2 are equipped with built-in choke as standard. For frames A and B, the ACS850 drives

do not necessarily need a separate mains choke for operation. If, however, a separate mains choke is needed, mains chokes are available according to the following table.

Frame size	Drive type designation	Type	Dimensions						Weight	
			Width		Length		Depth		kg	lb
			mm	in	mm	in	mm	in		
A	ACS850-04-03A0-5	CHK-01	120	4.72	146	5.75	79	3.11	1.8	4.0
A	ACS850-04-03A6-5	CHK-01	120	4.72	146	5.75	79	3.11	1.8	4.0
A	ACS850-04-04A8-5	CHK-02	150	5.91	175	6.89	86	3.39	3.8	8.4
A	ACS850-04-06A0-5	CHK-02	150	5.91	175	6.89	86	3.39	3.8	8.4
A	ACS850-04-08A0-5	CHK-02	150	5.91	175	6.89	86	3.39	3.8	8.4
B	ACS850-04-010A-5	CHK-03	150	5.91	175	6.89	100	3.39	5.4	11.9
B	ACS850-04-014A-5	CHK-03	150	5.91	175	6.89	100	3.39	5.4	11.9
B	ACS850-04-018A-5	CHK-04	150	5.91	175	6.89	100	3.39	5.2	11.5

Resistor braking

Depending on the application, an external braking resistor may be needed to dissipate the generated kinetic energy thermally. For this, ACS850 uses its braking chopper and external braking resistor.

providing the specified resistance value is not decreased, and the heat dissipation capacity of the resistor is sufficient for the drive application.

For ACS850 drives, no separate fuses in the brake circuit are required if the following conditions are met:

Brake chopper

The ACS850 series has built-in brake choppers in frames A to D (up to 45 kW [60 hp] at 400 V) as standard. Above this, brake choppers are available as built-in options.

- The ACS850 mains cable is protected by fuses
- No mains cable/fuse overrating takes place

Brake resistor

Preselected brake resistors are separately available for all ACS850 types. Resistors include integrated thermal sensor as standard. Resistors other than standard offering may be used

Brake chopper				Brake resistors				Type designation	Frame size
Cyclic (base load P_{HD})		Cont.	Peak	R_{min}	E_r	P_N	Type		
P_{brs} kW	P_{br10} kW	P_{brcont} kW	P_{brpk} kW	Ohm	KJ	W			
$U_N = 230 V$									
0.5	0.5	0.45	2.75	120	22	105	JBR-01	ACS850-04-03A0-2	A
0.75	0.7	0.65	2.75	120	22	105	JBR-01	ACS850-04-03A6-2	A
1.0	1.0	0.9	2.75	120	22	105	JBR-01	ACS850-04-04A8-2	A
1.5	1.4	1.3	2.75	120	22	105	JBR-01	ACS850-04-06A0-2	A
1.5	1.4	1.3	2.75	120	22	105	JBR-01	ACS850-04-08A0-2	A
2.8	2.7	2.25	4.0	80	40	135	JBR-03	ACS850-04-010A-2	B
4.1	3.9	3.3	7.3	40	73	360	JBR-04	ACS850-04-014A-2	B
5.3	5.1	4.25	7.3	40	73	360	JBR-04	ACS850-04-018A-2	B
6.8	6.5	5.25	15.4	20	77	570	JBR-05	ACS850-04-025A-2	C
7.8	7.4	6	15.4	20	77	570	JBR-05	ACS850-04-030A-2	C
7.8	7.4	6	15.4	20	77	570	JBR-05	ACS850-04-035A-2	C
11.4	10.8	8.75	22.0	13	132	790	JBR-06	ACS850-04-044A-2	C
11.4	10.8	8.75	22.0	13	132	790	JBR-06	ACS850-04-050A-2	C
20.2	20.0	18	22.0	13	132	790	JBR-06	ACS850-04-061A-2	D
20.2	20.0	18	22.0	13	132	790	JBR-06	ACS850-04-078A-2	D
20.2	20.0	18	22.0	13	132	790	JBR-06	ACS850-04-094A-2	D

Options

Mains circuit



Brake chopper				Brake resistors				Type designation	Frame size
Cyclic (base load P_{Hd})		Cont.	Peak	R_{min} Ohm	E_r KJ	P_N W	Type		
P_{br5} kW	P_{br10} kW	$P_{br,cont}$ kW	$P_{br,pk}$ kW						
$U_N = 400 V$									
1.0	1.0	0.9	5.5	120	22	105	JBR-01	ACS850-04-03A0-5	A
1.5	1.4	1.3	5.5	120	22	105	JBR-01	ACS850-04-03A6-5	A
2.0	1.9	1.8	5.5	120	22	105	JBR-01	ACS850-04-04A8-5	A
3.0	2.8	2.6	5.5	120	22	105	JBR-01	ACS850-04-06A0-5	A
3.0	2.8	2.6	5.5	120	22	105	JBR-01	ACS850-04-08A0-5	A
5.5	5.3	4.5	7.9	80	40	135	JBR-03	ACS850-04-010A-5	B
8.2	7.8	6.6	14.6	40	73	360	JBR-04	ACS850-04-014A-5	B
10.5	10.1	8.5	14.6	40	73	360	JBR-04	ACS850-04-018A-5	B
13.6	12.9	10.5	30.7	20	77	570	JBR-05	ACS850-04-025A-5	C
15.5	14.7	12	30.7	20	77	570	JBR-05	ACS850-04-030A-5	C
15.5	14.7	12	30.7	20	77	570	JBR-05	ACS850-04-035A-5	C
22.7	21.5	17.5	43.9	13	132	790	JBR-06	ACS850-04-044A-5	C
22.7	21.5	17.5	43.9	13	132	790	JBR-06	ACS850-04-050A-5	C
40.4	40.0	36	43.9	13	132	790	JBR-06	ACS850-04-061A-5	D
40.4	40.0	36	43.9	13	132	790	JBR-06	ACS850-04-078A-5	D
40.4	40.0	36	43.9	13	132	790	JBR-06	ACS850-04-094A-5	D
67.5	66	61	-	8	1800	4500	SAFUR90F575	ACS850-04-103A-5	E0
85	83	75	-	6	2400	6000	SAFUR80F500	ACS850-04-144A-5	E0
-	-	112.5	-	4	3600	9000	SAFUR125F500	ACS850-04-166A-5	E
-	-	135	-	4	3600	9000	SAFUR125F500	ACS850-04-202A-5	E
-	-	135	-	4	3600	9000	SAFUR125F500	ACS850-04-225A-5	E
-	-	160	-	4	3600	9000	SAFUR125F500	ACS850-04-260A-5	E
-	-	200	-	2.7	5400	13500	SAFUR200F500	ACS850-04-290A-5	E
-	-	250	-	2	*	*	*	ACS850-04-387A-5	G1
-	-	250	-	2	*	*	*	ACS850-04-500A-5	G1
-	-	355	-	1.3	*	*	*	ACS850-04-580A-5	G1
-	-	355	-	1.3	*	*	*	ACS850-04-650A-5	G1
-	-	400	-	0.7	*	*	*	ACS850-04-710A-5	G2
-	-	400	-	0.7	*	*	*	ACS850-04-807A-5	G2
-	-	400	-	0.7	*	*	*	ACS850-04-875A-5	G2

- = not available

* Contact your local ABB representative

Maximum braking power of the ACS850 drive equipped with standard chopper and resistor

P_{br5}	5 s/1 min
P_{br10}	10 s/1 min

The braking energy transmitted to the resistor during any period shorter than 400 seconds may exceed E_r (E_r varies depending on the resistor).

$P_{br,cont}$ Continuous brake chopper power. The value applies to the minimum resistance value. With a higher resistance value the $P_{br,cont}$ may increase in some ACS850 drives.

R Resistance value for the listed resistor type. Note: This is also the minimum allowable resistance value for the brake resistor.

$P_{br,pk}$ Maximum braking power of the drive (inverter and chopper). The drive (inverter and chopper) will withstand this braking power for 1 second within every 10 seconds.
Note: The listed resistors will withstand this braking power for 1 second within every 120 seconds.

E_r Energy pulse that the resistor assembly will withstand (400 seconds duty cycle). This energy will heat the resistor element from 40 °C (104 °F) to the maximum allowable temperature.

P_{cont} Continuous power (heat) dissipation of the resistor when placed correctly. Energy E_r dissipates in 400 seconds.

All brake resistors are to be installed outside the converter module.

The SAFUR brake resistors are built-in in an IP00 metal frame.

Options

Mains circuit



du/dt filters

du/dt filtering suppresses inverter output voltage spikes and rapid voltage changes that stress motor insulation.

Additionally, du/dt filtering reduces capacitive leakage currents and high frequency emission of the motor cable as well as high frequency losses and bearing currents in the motor.

The need for du/dt filtering depends on the motor age and insulation. For information on the construction of the motor insulation, consult the motor manufacturer. If the motor does not fulfil the requirements of the filter selection table, the lifetime of the motor might decrease. Insulated non-driven end (N-end) bearings and/or common mode filters are also required for motor bearing currents with motors bigger than 100 kW. For more information please see the ACS850 hardware manual.

External du/dt filters

ACS850-04		du/dt filter type (3 filters included in kits marked *)							
		Unprotected (IP00)							
230 V	500 V	NOCH0016-60	NOCH0030-60	NOCH0070-60	* NOCH0120-60	* NOCH0260-60	FOCH0260-70	FOCH0610-70	FOCH875-70
-03A0-2	-03A0-5	■	-	-	-	-	-	-	-
-03A6-2	-03A6-5	■	-	-	-	-	-	-	-
-04A8-2	-04A8-5	■	-	-	-	-	-	-	-
-06A0-2	-06A0-5	■	-	-	-	-	-	-	-
-08A0-2	-08A0-5	■	-	-	-	-	-	-	-
-010A-2	-010A-5	■	-	-	-	-	-	-	-
-014A-2	-014A-5	■	-	-	-	-	-	-	-
-018A-2	-018A-5	■	-	-	-	-	-	-	-
-025A-2	-025A-5	-	■	-	-	-	-	-	-
-030A-2	-030A-5	-	■	-	-	-	-	-	-
-035A-2	-035A-5	-	■	-	-	-	-	-	-
-044A-2	-044A-5	-	-	■	-	-	-	-	-
-050A-2	-050A-5	-	-	■	-	-	-	-	-
-061A-2	-061A-5	-	-	■	-	-	-	-	-
-078A-2	-078A-5	-	-	■	-	-	-	-	-
-094A-2	-094A-5	-	-	-	■	-	-	-	-
	-103A-5	-	-	-	■	-	-	-	-
	-144A-5	-	-	-	■	-	-	-	-
	-166A-5	-	-	-	■	-	-	-	-
	-202A-5	-	-	-	-	■	-	-	-
	-225A-5	-	-	-	-	-	■	-	-
	-260A-5	-	-	-	-	-	■	-	-
	-290A-5	-	-	-	-	-	■	-	-
	-387A-5	-	-	-	-	-	-	■	-
	-500A-5	-	-	-	-	-	-	■	-
	-580A-5	-	-	-	-	-	-	■	-
	-650A-5	-	-	-	-	-	-	■	-
	-710A-5	-	-	-	-	-	-	■	-
	-807A-5	-	-	-	-	-	-	-	■
	-875A-5	-	-	-	-	-	-	-	■

■ = option, external - = not applicable

du/dt filter selection table

Motor type	Nominal mains voltage (U_N)	Motor insulation requirement
ABB M2 and M3 motors	$U_N \leq 500$ V	Standard insulation system.
ABB form-wound HXR and AM motors	380 V < $U_N \leq 500$ V	Standard insulation system.
ABB random-wound HXR and AM motors	380 V < $U_N \leq 500$ V	Check motor insulation system with the motor manufacturer.
Non-ABB random-wound and form-wound	$U_N \leq 420$ V	If the insulation system withstands $\hat{U}_{LL} = 1600$ V and $\Delta t = 0.2$ μ s, du/dt filtering is not required. With du/dt filtering the insulation system must withstand $\hat{U}_{LL} = 1300$ V.

U_N = Nominal mains voltage.

\hat{U}_{LL} = Peak line-to-line voltage at motor terminals.

Δt = Rise time, ie, interval during which line-to-line voltage at motor terminals changes from 10% to 90% of full voltage range.

Dimensions and weights of du/dt filters

du/dt filter	Height		Width		Depth		Weight	
	mm	in	mm	in	mm	in	kg	lb
NOCH0016-60	195	7.7	140	5.5	115	4.5	2.4	5.28
NOCH0030-60	215	8.5	165	6.5	130	5.1	4.7	10.34
NOCH0070-60	261	10.3	180	7.1	150	5.9	9.5	20.9
NOCH0120-60*	200	7.9	154	6.1	106	4.2	7	15.4
NOCH0260-60*	383	15.1	185	7.3	111	4.4	12	26.4
FOCH0260-70	382	15.0	340	13.4	254	10.0	47	103.4
FOCH0610-70	662	26.1	319	12.6	282	11.1	65	143
FOCH875-70	662	26.1	319	12.6	292	11.5	65	143

* 3 filters included, dimensions apply for one filter.

Options

PC tools

DriveStudio

User-friendly PC tool for quick drive startup, drive tuning and advanced programming tasks.

Startup and maintenance tools:

- Fast parameter navigation
- Parameter setting
- **Local logging and online drive signal monitoring of multiple signal channels for drive tuning**
- Backup and restore tool for drive parameter and DriveSPC program cloning
- Case sensitive help with detailed descriptions of drive parameters, events and functions
- Overview of the drive performance and status

DriveSPC

DriveSPC is a programming tool that enables easy modification or extension of drive functionality:

- Simple, easy-to-learn function block interface showing drive firmware functions, signals and parameters
- **Easy to add user-defined function block programs even for the fast time levels of the drive control**
- Function block programming with standard IEC61131 function block library
- Professional programming environment with hierarchy levels, custom circuits, user parameters and copy protection of DriveSPC programs

DriveSize

DriveSize is a PC program for helping the user select the optimal motor, frequency converter and transformer, especially in the case where a straightforward selection from a catalog is not possible. Additionally it can be used to compute currents, network harmonics and to create documents about the dimensioning based on actual load.

DriveSize contains the current versions of the ABB motor and AC drive catalogs.

The default values make DriveSize simple to use, and the user is provided with ample options for drive selection. The shortcut keys make drive selection easy while giving the optimal dimensioning result. A manual selection mode is also supported.

DriveSize features:

- Selects the optimal motor, drive unit, supply unit and transformer
- **Calculates network harmonics for a single supply unit or for the whole system**
- Allows importing of own motor database
- **Supplies dimensioning results in graphical and numerical format**
- Prints and saves the results

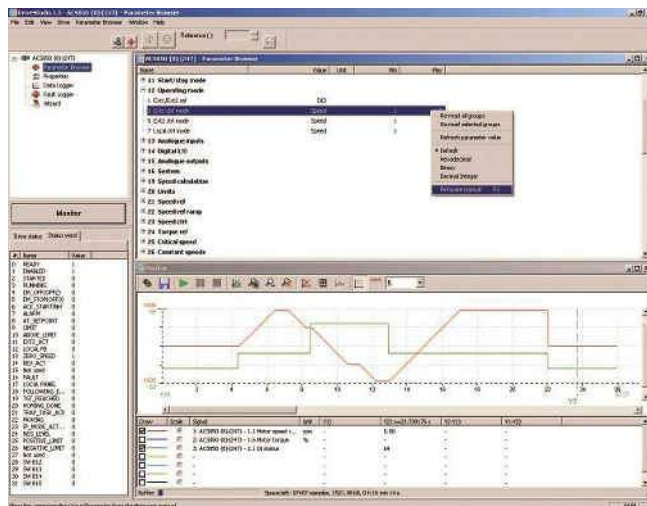

DriveStudio

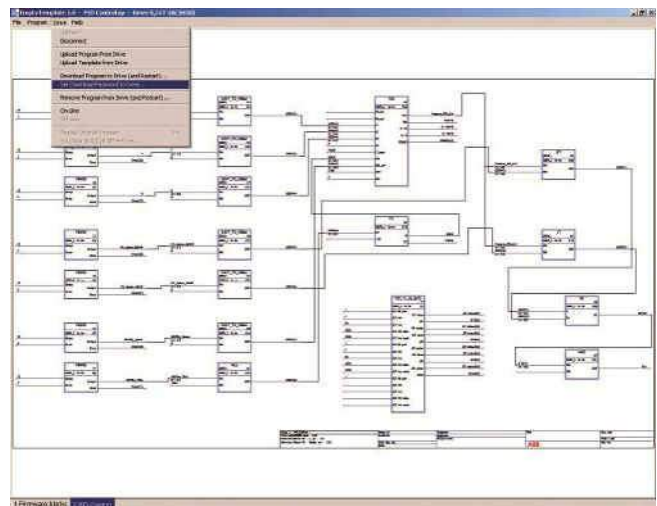

DriveSPC

Options

Crane control program (+N5050 +N3050)

Dedicated AC drives for standalone crane applications

Standalone cranes that require independent movements can benefit from using ACS850 with crane control program. This combination provides stepless speed and torque control of the crane along with control of the mechanical brake and other crane functionality.

Crane applications that can benefit from these functions, whether new or retrofit are:

- Tower cranes in hoist, trolley and slew motions
- Industrial cranes in hoist, trolley and long travel motions

Flexible usability with the crane control program

The ready-made crane control program can interface with analog, digital or fieldbus systems, enabling a wide range of connectivity for start, stop and reference change signals. The program includes four different user sets for customizing the parameter settings for multiple configurations. Each user set includes two different control places and an overriding emergency control place.

Crane control program features

- Mechanical brake control for improved safety
- Reference handling flexibility with joystick
- Enhanced safety with motor speed matching and overspeed protection
- Load speed control optimizes crane capacity
- Safety control to keep the crane within limits (slowdown end limit)
- Slack rope detection to increase safety on crane drums
- Function block programming by example: functions (SPL)
- Homing mode for defining position of crane or hook
- Crane load analyzer to monitor loading
- Maintenance counters
- Support for conical motors
- Brake match for improved safety with mechanical brakes

Ordering

The crane control program can be ordered using option code +N5050 for crane control program and +N3050 for crane technology library.



Options

Synchronous reluctance motor and drive package (+N7502)

SynRM – Synchronous reluctance motor and drive package

The idea is simple. Take a conventional proven stator technology and a totally new, innovative rotor design. Then combine them with a best-in-class industrial drive loaded with new, purpose-designed software. Finally, optimize the whole package for pump and fan applications.

- The performance of a permanent magnet motor together with the cost-efficiency, simplicity and service-friendliness of an induction motor
- Synchronous reluctance technology delivers better power density and higher energy efficiency than with the equivalent induction motors
- Cool rotor running keeps motor bearing temperature very low, which extends bearing lifetime and service intervals
- Drive setup is as easy as with induction motors. Parameters from the motor nameplate are just entered in to the drive. No feedback devices like encoders or positions sensors are needed.
- SynRM packages combine a matched motor & drive, and the latest software. Selection is made easy with pre-selected packages.
- The SynRM motor and drive packages are measured to verify package efficiency

Ordering

The ACS850 machinery drive with direct torque control (DTC) supports the new synchronous reluctance motors. The SynRM motor control can be ordered using the option code +N7502. For current motor availability please contact your local ABB representative.



ABB synchronous reluctance motor



Synchronous reluctance motor and ACS850

Options

Remote monitoring and diagnostic tools

SREA-01 enables remote access

With drives increasingly being installed in remote locations, it is vital that operational and process data is monitored locally in real time and transmitted to a central location for analysis. Often there is no qualified service personnel stationed at these sites, which makes remote monitoring and diagnosis of the drive and application crucial to process availability. The SREA-01 Ethernet adapter performs all these remote access tasks.

Designed as an optional remote interface module for the drives, the SREA-01 can send process data, data logs and event messages independently, without a PLC or a dedicated on-site computer, and has an internal web server for configuration and drive access.

Connecting multiple drives to an Ethernet or GPRS network

In addition to a standard Ethernet port, the SREA-01 has a serial port for connection to a standard GSM/GPRS modem for Internet connectivity in isolated places. The modem connection enables sending e-mail or SMS messages, uploading data files by FTP, or accessing the SREA-01 web pages.

The SREA-01 is connected to the panel port, or alternatively to the Modbus interface, of a drive. A maximum of 10 drives can be connected to a single SREA-01 module over Ethernet or EIA-485 serial communication networks. Simultaneous use of the two connection methods is possible, allowing access to different types of drives. In addition, Modbus TCP commands from a PLC to a drive are supported in the remote monitoring mode.

Collecting data logs and integrating drive data in SCADA applications

For collecting data from the drive, process or data analysis, the SREA-01 has a configurable data logger that can store values in memory or to a file, with sample intervals between ten seconds and one hour. The files are stored internally for visualization with a web browser. Data in standard comma separated values (CSV) file format can be imported to applications such as Microsoft Excel for processing.

The collected data logs can be sent by e-mail or FTP, either through a local area network or the Internet. The sending interval can be configured by the user with logs sent, for example, hourly or weekly. In addition to its data logging functionality, the SREA-01 also has an internal Modbus TCP gateway, providing a standard interface that can be used by supervisory control and data acquisition (SCADA) applications to display drive information in real time.

Receiving event messages and alarms, and accessing the drive remotely

The SREA-01 can be used to monitor the drive and application parameters such as process temperatures, and send alarm messages to maintenance personnel if a set limit is exceeded. Event and alarm messages are sent as SMS messages or by e-mail using the user's own messages. The event conditions and messages can be configured by the user to make them suitable for a number of applications.

At any time, the internal web server of the SREA-01 provides an intuitive user interface for accessing the drives. Travel to sites can often be avoided by using a standard web browser to view and change the drive parameters, monitor the status of all connected devices, and browse the actual faults or history of the installation.



Expertise at every stage of the value chain



Whether you operate in industry, commerce or a utility your aims remain the same: to keep your motor-driven applications running consistently and efficiently. The life cycle services for ABB drives can help you achieve these aims by maximizing the uptime of your process while ensuring the optimum lifetime of ABB drives in a predictable, safe and low-cost manner.

The life cycle services for ABB drives span the entire value chain, from the moment you make the first enquiry about a drive through to its disposal and recycling. Throughout the value chain, ABB provides training and learning, technical support and contracts. All of this is supported by one of the most extensive global drive sales and service networks.

Secure uptime throughout the drive life cycle

ABB follows a four-phase model for the life cycle management of its drives. The life cycle phases are active, classic, limited and obsolete. Within each phase, every drive series has a defined set of services.

The four-phase drive life cycle management model provides you with a transparent method for managing your investment in drives. In each phase, you clearly see what life cycle services are available, and more importantly, what services are not available. Decisions on upgrading, retrofitting or replacing drives can be made with confidence.

ABB drive life cycle management model

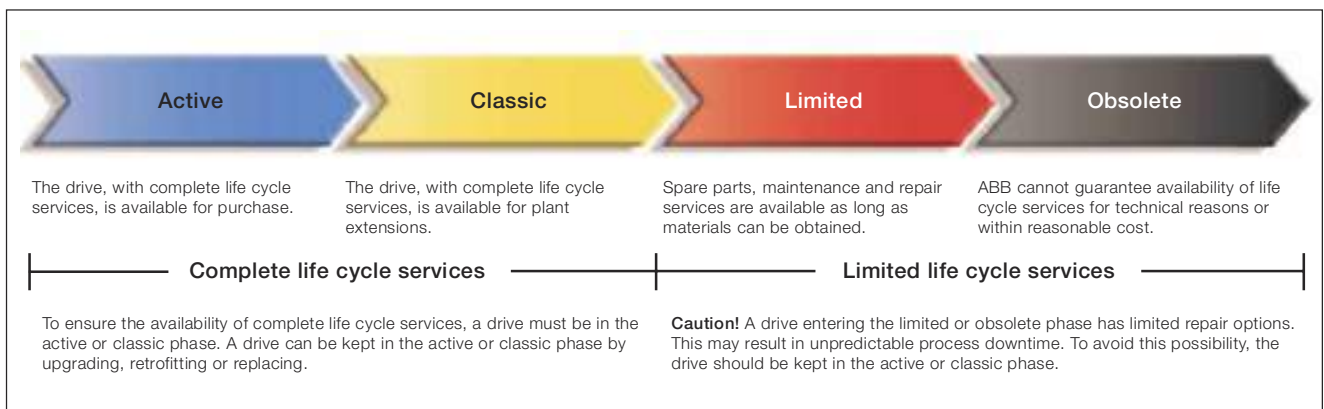

Contact us

For more information please contact your local ABB representative or visit:

www.abb.com/drives

www.abb.com/drivespartners

© Copyright 2013 ABB. All rights reserved.
Specifications subject to change without notice.

3AUA0000041481 REV H EN 5.9.2013 # 16884